



AXR-H



GB – 400/500/600 cm
SERIE NR: 1550 - XXXX

DAL-BO AXR-H

Type, 400, 500, 600 cm

Congratulations on your new AXR-H disc harrow. To ensure **safe operation** and to obtain optimal use of the machine, read the rules and instructions of the following operator's manual carefully **before operating the machine**.

© Copyright 1995, DAL-BO. All rights reserved.

Important safety information is preceded by a ▽

- ▽ Tighten all nuts, bolts, hydraulic fittings or any other fastened assemblies after a few hours' use.
- ▽ Operate the machine only while seated in the driver's seat of the tractor. Never allow anyone to be in the immediate vicinity of the operating area of AXR-H.
- ▽ Never allow children to operate the equipment.
- ▽ The AXR-H must be secured in the transport position while being towed on public roads.
- ▽ The driver is responsible for the correct use of lights and markings in compliance with the present Traffic Act and Highway Code of the local traffic legislation.

Your AXR-H has:

Serial number: _____ Type description: _____
Month of manufacture: _____ Net weight (kg): _____

For prompt service, always quote your machine serial number when making enquiries regarding spare parts or service. A comprehensive index of spare parts can be found in the back of this manual to give you an overview of AXR-H components and to facilitate ordering.

EC DECLARATION OF CONFORMITY

DAL-BO A/S
DK-7183 Randbøl

Hereby declare that the above-mentioned machine has been manufactured in compliance with the provision of the Council Directive on the approximation of the laws of the Member States relating to Machinery 98/37/EF, which replaces Council Directive 89/392/EØF and amendments 91/368/EØF, 93/44/EØF and 93/68/EØF with special reference to Annex 1 of the Directive concerning the Essential Health and Safety Requirements for the design and the manufacture of Machinery.

DAL-BO A/S

Date: _____

Director Kaj Pedersen

Table of Contents

TABLE OF CONTENTS	4
USAGE	6
ADVANTAGES OF THE AXR-H.....	6
SAFETY INSTRUCTIONS	7
HOOK-UP AND DISMOUNTING	8
HOOK-UP	8
<i>Hydraulics</i>	8
DISMOUNTING.....	9
HANDLING WITHOUT TRACTOR LIFT ARMS	9
<i>Table 2, Total Weight in kg</i>	9
ADJUSTMENTS AND SETTINGS.....	10
DEPTH ADJUSTMENT.....	10
DISC ANGLING	11
SCRAPERS.....	11
OUTER HARROWS	11
<i>Mounting</i>	12
<i>Adjustment</i>	12
DRAWBAR	12
OPERATING AND DRIVING INSTRUCTIONS.....	13
FOLDING AND UNFOLDING	13
LEVELLING POSITION	14
<i>Ridge along the middle</i>	14
PENETRATION DEPTH.....	15
TRAVEL SPEED	16
<i>Power Requirements</i>	16
TROUBLESHOOTING	17
MAINTENANCE	18
LUBRICATION.....	18
SAFETY INSTRUCTIONS	19
REPLACEABLE WEARING PARTS.....	19
ADJUSTMENTS.....	19
<i>Adjustment of the castle nuts on the side wing pivots</i>	19
WHEELS	20
<i>Dismounting/mounting of wheels</i>	20
<i>Adjustment and lubrication of wheel bearings</i>	20
GENERAL INFORMATION	20
<i>Cleaning and Inspection</i>	20
OPTIONS	21
HYDRAULIC ANGLE ADJUSTMENT	21
<i>Mounting</i>	21
<i>Operating Instructions</i>	21
<i>Maintenance</i>	22
ELECTRO-HYDRAULIC OPERATION	22
BEARING PROTECTORS	23
<i>Mounting</i>	23
REPLACEMENTS AND REPAIRS.....	24
REPLACING DISC BEARINGS	24

<i>Mounting discs and bearings</i>	25
<i>Replacing the bearings in the housings</i>	27
REPLACING T-RING PACKER ROLLER BEARINGS	28
REPLACING SCRAPERS	28
<i>Packer Roller Scrapers</i>	28
<i>Disc scrapers</i>	29
REPLACING DISCS	29
REPLACING T-RINGS	29
REPLACING DRAWBAR BUSHINGS	29
<i>Mounting</i>	30
REPLACING PACKER ROLLER ARM BUSHINGS	30
REPLACING PACKER ROLLER CENTRE PIN	31
DISMOUNTING DISC GANGS	31
REPLACING HYDRAULIC HOSES	32
REPLACING SIDE WING FOLDING CYLINDERS	32
<i>Changing the seals on the side wing folding cylinders</i>	32
<i>Assembly</i>	33
REPLACING WHEEL FRAME CYLINDER	34
<i>Changing the seals on the wheel frame cylinder</i>	34
<i>Assembly</i>	35
REPLACING PACKER ROLLER FOLDING CYLINDERS	35
<i>Changing the seals on the packer roller cylinder</i>	35
<i>Assembly</i>	36
REPLACING ANGLE ADJUSTMENT CYLINDERS	37
<i>Changing the seals on the angle adjustment cylinders</i>	37
<i>Assembly</i>	38
REPLACING HYDRAULIC LOCK CYLINDERS ON THE DISC GANGS	38
<i>Changing the seals on the hydraulic lock cylinders</i>	39
<i>Assembly</i>	39
REPLACING WHEEL BEARINGS	39
<i>Assembly</i>	40
HYDRAULIC DIAGRAM 400/500/600	41
SCRAPPING	42
SPAREPARTS	43

Usage

The AXR-H is a rugged disc harrow that is designed to cut, mix and pulverise plant stubble and plant residue. The AXR-H performs particularly well when breaking down large quantities of straw and plant residue, since the implement will never drag or become plugged with plant material.

The AXR-H is constructed on a heavy-duty main frame onto which the disc gangs are mounted in an offset X formation. A two-section roller consisting of 60-cm steel rings and scrapers is suspended from the very back of the tool.

A special feature of the AXR-H is the dual depth control system. Penetration depth can be controlled both by the lift arms of the tractor and by the packer roller attachment. This special implement design provides smooth and steady fieldwork. The working depth can be precisely controlled, which results in a field surface that is even and uniformly packed without any trace of wheel tracks.

The AXR-H is an effective tool for plough-free cultivation, and at the same time it conditions the soil for an ideal seedbed. A seed drill with a working width of 4 and 5 m can be mounted as an optional accessory.

The AXR-H can also be equipped with optional accessories such as hydraulic depth adjustment, hydraulic angle adjustment and electro-hydraulic operation.

Advantages of the AXR-H

- Notch-less depth adjustment from 4 to 20 cm.
- **No** bearing wheels to cause uneven field packing.
- Field is left even, with a uniform blend of soil and plant residue.
- Retains soil moisture.
- Heavy machine weight.
- Changeable parts have a long lifetime.

The AXR-H is particularly well suited to work in the topsoil where the greatest amount of work on plant residue takes place. Only one pass is needed with the AXR-H to thoroughly and effectively penetrate the fields and evenly mix plant residue together with the microorganisms in the soil. To preserve the moisture of the soil and thereby provide the organisms of the soil with an ideal microclimate, field work is completed with a packer.

Safety Instructions

- ▽ The AXR-H must only be used for ordinary field work. The AXR-H must not be used for clearing forests, breaking up roads or any other similar activity. If you have any questions regarding the proper operation of the AXR-H, contact your local dealer or Maskinfabrikken DAL-BO A/S.
- ▽ The AXR-H must not be used as a crane, a post driver, a hydraulic press or anything similar.
- ▽ Operate the tractor and AXR-H only while seated in the driver's seat.
- ▽ Never allow anyone to ride on the implement.
- ▽ A higher level of noise is produced when driving on rocky soil. This level is well under the danger level for the tractor driver.
- ▽ Driving on extremely dry soil conditions can raise a large amount of dust. It is recommended that the windows and doors of the tractor be closed or that a dust mask be used.

Hook-up and Dismounting

The linkage of the AXR-H is manufactured in compliance with DS/ISO 730-1 category II and III. If the lift of your tractor is not equipped for this, contact your DAL-BO representative.

Hook-Up

First mount the lift arms into the ball sockets (A). Elevate the lift and move the hitch jack up into the transport/working position (B).

Fig. 1



▽

Remember to secure the lift arms and the hitch jack with lynch pins. Adjust the sway chains tightly until there is no slack in the lift arms.

Hydraulics

There are varying requirements for hydraulic connections depending on the type of AXR-H model (see "Options"). The standard model requires two double-acting services: one set for wing folding/unfolding and the other set for the wheel frame.

Table 1, **Hydraulic hose markings**

Function	Colour
Wheels	Yellow
Folding/Unfolding DISC	Red
Folding/Unfolding PACKER	Green
*Angel adjustment	Blue

*Not standart.

Connect the hydraulic hoses to the double-acting 1/2" sockets located on the lift.

Dismounting

▽

The AXR-H must be secured with the transport locks or it must be unfolded before dismounting. Remember to relieve the pressure in the connecting hose to the hydraulic system before disconnecting it.

Dismount in reverse order to hook-up.

Handling without tractor lift arms

If you need to move the AXR-H other than by use of the three-point hitch, we recommend lifting it with straps around the middle section, raising the machine so that it hangs in balance.

Table 2, **Total Weight in kg**

Type	400 cm	500 cm	600 cm
AXR-H	4.320	4.700	5.500

Adjustments and Settings

The AXR-H is preset in the factory, but it will always be necessary to make some fine adjustments before use. The numerous adjustment possibilities make your AXR-H more versatile, and allow you to get optimum performance from the implement.

A combination spanner is provided for the adjustment of the spindles and for the tightening of the castle nuts.

Fig. 2



Depth Adjustment

The working depth can be adjusted on the lift and on the rear T-ring packer roller.

Fig. 3



To increase the working depth, shorten the cylinders. To decrease the working depth, the cylinders must be longer. The depth indicators show the depth reading, which must be equal on both packer roller sections.

Disc Angling

The angle of the discs can be adjusted according to need. As a standard position, set the front and rear gangs at the same angle.

Adjust the angle of the discs by lengthening or shortening the turnbuckles located between the main frame and the disc gangs. Remember to tighten the tightening nut on the turnbuckle.

Fig. 4



Scrapers

Adjust the scrapers by loosening the bolts (A), so that the scrapers can be moved. Adjust the scrapers so that there is a minimum space of 5 mm between the scrapers and the discs, but make sure that the scrapers never touch the discs.

Fig. 5



The design of the scrapers ensures that they maintain the correct angle in relation to the discs.

Outer Harrows

Mounting the outer harrows limits the amount of soil and plant residue that is cast out to the side by the outermost discs of the front disc gangs. Outer harrows are designed to prevent soil and plant residue from being cast out beyond the reach of the rear discs.

Outer harrows afford you greater freedom with respect to travel speed since soil and residue are always kept within the reach of the AXR-H regardless of speed. Fields can easily be left more even through the mounting outer harrows.

Fig. 10



Mounting

Outer harrows are held by two pipes that are mounted into the scraper fittings. The outer harrows are mounted like a sliding beam attachment.

Adjustment

The distance between the outermost disc and the fingers of the outer harrows can be adjusted with a pin (A), using approximately 30 cm as a standard setting. Remember to insert the split cotter pin again.

Fig. 11

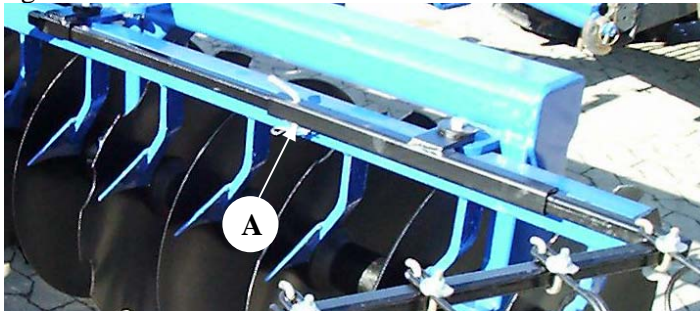

Drawbar

The drawbar can be adjusted vertically. More adjusting can be made by turning the drawbar upside down.

Fig. 12

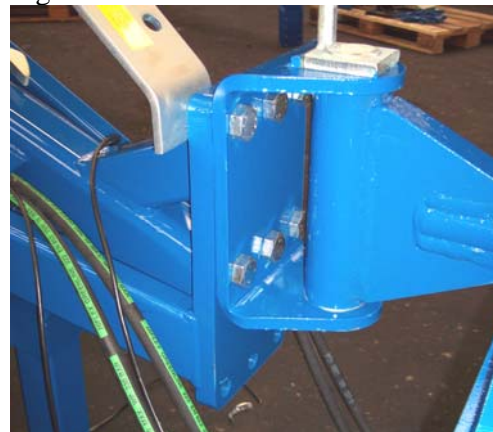

Operating and Driving Instructions

Proper operation is essential to attain the optimum performance from your AXR-H. Proper operation entails both carrying out tillage operations in the field correctly as well as following safety precautions.

- ▽ **Every day before operating the AXR-H, inspect all pins, nuts, bolts and connections to be sure that all are tightened and securely in place.**
- ▽ **Keep all bystanders away from the operating radius of the implement when unfolding.**
- ▽ **Always be sure the AXR-H is in the proper position for transport when transporting the implement on public roads.**
- ▽ **The AXR-H must be in the fully raised position on both liftarms and wheel frame when moving in reverse or turning around.**
- ▽ **Never load extra weight onto the AXR-H.**

The AXR-H is an effective land manager and it is capable of mixing a large quantity of soil and plant residue. However, in addition to this effective land treatment, proper driving and equipment settings are required to ensure that the fields will be left uniformly level and without any ridges. Resulting surface conditions can vary depending on how you operate the tool.

The outermost disc in the front must run 5-10 cm from the preceding trail in order to obtain the optimum performance of the machine and to achieve a level field surface.

Folding and Unfolding

Fold and unfold the wings of the AXR-H while the equipment is stationary.

The mechanical transport locks are engaged and disengaged when the side wings are folded and unfolded between the transport and the working position. Upon arrival to the working area, activate the handle for the folding/unfolding of the side wings. Make sure that the side sections are fully raised. Release the transport lock by activating the handle to the wheel cylinder so that the cylinder is pressed out to the fully extended position. The transport locks will be released, and the side wings together with the packer roller can then be unfolded.

Make sure that the side wings and the packer roller are completely unfolded and that there is pressure in the cylinders before lowering the disc harrow into/onto the ground. The locks for the disc gang are used if needed.

Levelling Position

In the standard levelling position, the AXR-H must be adjusted to operate in a perfectly level and horizontal position, both side-to-side and front-to-rear. The AXR-H must lie straight across, i.e., perpendicular (90°) to the line of travel of the tractor. It must also be level front-to-rear or in a parallel direction, i.e., the lift arms on the tractor hitch should be parallel to the ground. **It is important to maintain this levelling position to obtain level and uniform field finishing.**

The discs can be angled according to need. For heavy work, set the disc gangs at a larger angle, so that deeper cut and penetration is achieved throughout the full extent of the cutting width.

In the levelling position, adjust the gangs in the very front and in the very back to have the same angle. There are four notches on the gang pivots which indicate the angle of the disc gangs. Count the notches moving from (A) towards (B), and set the pivots at the same notch position in order to set the same angle on the gangs. (See "Adjustments and Settings, Disc Angling") Remember to tighten the tightening nut on the turnbuckle.

Fig.14

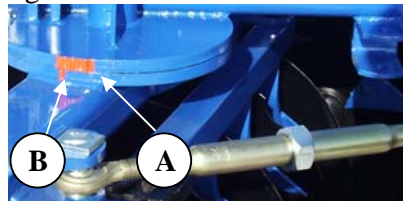

Front disc gang

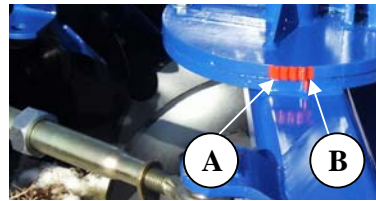

Rear disc gang

When working on hard, dry soil, it is recommended that the deepest cut/most aggressive setting be used (B, fig. 10), but when working on loose soil and under wet conditions, a more passive setting is appropriate (A). The more angle you have the more aggressive the cut will be and the more tractor power will be required to pull the implement. Thus, the discs should not be set more aggressively than necessary in order to save on the wearing of the parts and the amount of tractive force needed.

Ridge along the middle

A ridge of soil may form in the middle under the AXR-H while driving. If this occurs, the angle of the rear disc gang is too large, or the lift might not be lowered enough, causing the AXR-H to tilt backwards.

For a better ground finish, good results are often achieved by angling the front gangs a little more aggressively than the rear gangs. The front discs break up the surface easier and enable the rear gangs to mix more effectively.

Ridges on the sides

If the front gangs are set too aggressively, ridges may form on the outside of the outermost discs. These ridges could also appear if the driving speed is too high, or if the lift is lowered too far down, causing the AXR-H to tilt forwards. (See "Options, Outer Harrows")

The angle of the AXR-H must be set to suit conditions. Depending on the type of land surface and the amount of moisture in the soil, it will be necessary to adjust the AXR-H in order to adapt the tool to the specific field that needs to be worked.

Penetration Depth

The AXR-H can be set for light tillage operations. Depth can be precisely controlled by means of the suspended packer roller sections as well as the position control of the tractor lift. The AXR-H can be set for very light soil cultivation at a depth of only 5 cm. If work is carried out at a depth of only 5 cm, best results will be achieved through a very aggressive angling of the discs, so that the full amount of the cut can be achieved.

Fig. 15



The working depth is controlled by moving the setting in the position control of the tractor lift and by adjusting the packer roller.

When starting up, first lower the tractor lift down to the chosen depth. Then, sink the rear of the AXR-H down using the wheel frame. This special control of the implement provides a uniform start and stop of tillage work at the headland.

While working in the field it is important that the AXR-H works parallel to the ground. The position control on the lift should be set for a fixed bottom stop position, so that the disc harrow is lowered to the same depth every time.

Travel Speed

To achieve optimum performance of the AXR-H, a working speed between 8 and 12 km/hour is recommended. **Always drive according to conditions.**

It should be noted that wear on the implement increases considerably when the travel speed is increased, especially under dry soil conditions. Damage to the discs may also result from driving too fast under unfavourable conditions.

Power Requirements

Selecting the proper size tractor ensures that the operating speed can also be maintained when driving uphill. Sufficient power uphill offers the advantage of leaving a uniform field surface which is important for further field conditioning.

Table 3, **Guidelines for power requirements in HP/KW**

Cutting width	400 cm	500 cm	600 cm
Power requirements	130/96	145/107	160/118

It is important to remember that power requirements change according to soil type, terrain and travel speed. In addition to these factors, disc angling and penetration depth also greatly influence tractor power consumption.

Troubleshooting

Table 4

Ridge in the middle	<ul style="list-style-type: none"> • AXR-H tilted too far backwards • Angle too wide on the rear disc gangs
Ridge on the sides	<ul style="list-style-type: none"> • Tilted too far forwards • Angle too wide on the front disc gangs • Travel speed too fast
Ridge on one of the sides	<ul style="list-style-type: none"> • Tilted toward one of the sides (packer setting) • Hydraulic depth adjustment must be reset to "0" • Imprecise driving (too much/little overlapping).
No penetration	<ul style="list-style-type: none"> • Angle too small on the disc gangs • Check depth adjustment
Side wings will not unfold	<ul style="list-style-type: none"> • Red quick-coupler is not set correctly • Wheel cylinders are not fully extended • Side wings are stuck in the transport locks. The side sections must first be fully raised to release the transport locks.

Maintenance

Proper maintenance ensures a long lifetime for the AXR-H and also optimum performance from the implement. To facilitate maintenance, grease fittings have been mounted on those locations where wear on the equipment is the greatest.

Tighten all nuts, bolts, hydraulic fittings or any other fastened assemblies after the first workday. Inspect all pins and bolts for wear or damage and make sure that all are securely in place to avoid any possible damage or breakdown of the machine.

Lubrication

The number of grease fittings that require lubrication varies according to the different AXR-H model. (See "Options").

Fig. 16

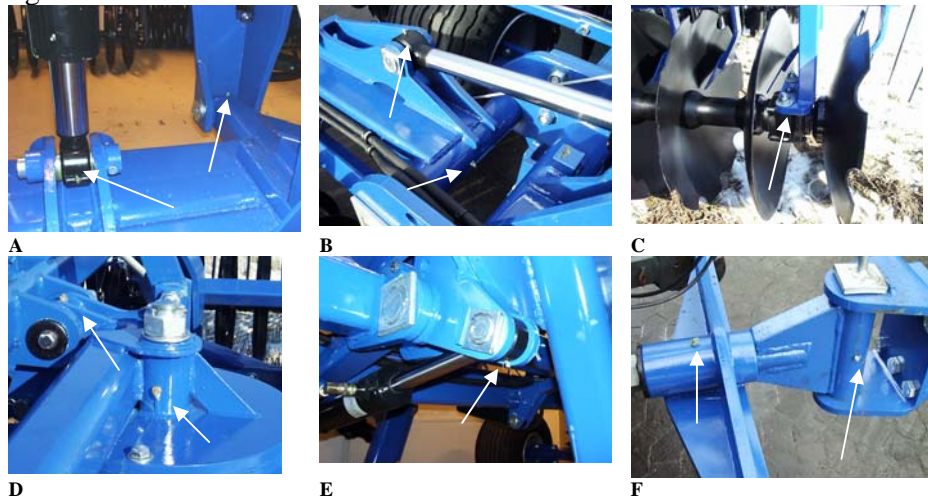

Table 5

Lubrication Points	Number of fittings	Lubrication interval (hours)	Photo
Wheel chassis suspension	2	Daily	A
Wheel chassis cylinder (top/bottom)	2	Daily	A
Packer roller cylinder, folding (top/bottom)	4	50	B
Packer roller pivot	2	Daily	
Centre pin for unfolding of packer roller	2	50	B
Centre pin to packer roller depth control	2	50	
Packer roller bearings	6	25	
Disc bearings	12	50	C
Disc angling pivots	4	50	D
Suspension bracket for wing folding/unfolding	4	50	D
Eye of cylinder for wing folding/unfolding	4	50	E
Drawbar, vertical/horizontal	2	Daily	F
Hydraulic angle adjustment, roller (options)	2	50	
Wheel bearing (see "Adjust. wheel bearings")		1 year	

Lubricate the packer roller pivots daily until the grease begins to come out from between the plates. This will press impurities out of the plates.

Safety Instructions

- ▽ It is **extremely dangerous** to work or walk under the AXR-H when it is raised in the transport position unless it is securely blocked or held into position. The engine of the tractor must be stopped and the brakes must be locked.
- ▽ Defective hydraulic hoses must be replaced immediately. A ruptured hose could cause personal injury to the user or mechanical damage to the equipment.
- ▽ Inspect all nuts, bolts, hydraulic fittings or any other fastened assemblies often to make sure that they remain thoroughly tightened.
- ▽ In case skin should come in contact with oil or grease or in case clothing should become stained with oil, remove the stained clothes immediately and wash the affected skin areas thoroughly. Oil and grease are harmful to the skin.

Replaceable Wearing Parts

The discs and scrapers are classified as replaceable wearing parts, but the wear on these parts is very limited. Changing of the replaceable parts is described under "*Replacements and Repairs*". To adjust the disc scrapers, see "*Scrapers*" under "*Adjustments and Settings*".

Adjustments

Adjustment of the castle nuts on the side wing pivots

The pivots are tightened to a torque of 100 Nm by the factory, but they must be tightened again if a gap develops between the plates.

The AXR-H must be completely lowered and unfolded before tightening the pivots.

1. Knock the slotted split pin (A) out of the shaft.
2. Tighten the castle nut (A) to a torque of 100 Nm, or until there is no longer a gap between the plates when the AXR-H is raised. Tighten the castle nut so that the hole in the axle lines up with the notches of the castle nut. Remember to insert the slotted split pin.

Fig. 17

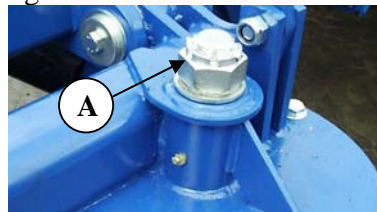

To protect the shaft and the pivot plates, a bolt (B) has been mounted inside an oblong slit. This bolt absorbs the pulling force that originates from the discs when the tractor begins to drive forward. This bolt (B) must be just loose enough that it can slide along the oblong slit when the angle of the discs is changed.

Wheels

Lubricate and adjust the wheel bearings once a year. Make sure that the tyre pressure is 3.9 bar for 500/55x15.5 14 ply tyres. If the AXR-H has been frequently in use both in the spring and in the autumn, the wheel bearings must be lubricated every six months. (See "*Dismounting/mounting of wheels*").

Dismounting/mounting of wheels

To dismount the wheels, lower the AXR-H until the discs are resting on the ground but still supported by the wheels, so that the hub nut can be loosened without causing the wheels to rotate. Next, lift the wheels clear off the ground and remove the hub nut completely. The wheel can then be removed and replaced. After mounting a new wheel, screw the nut on and tighten by hand. Next, lower the wheels until they are touching the ground and tighten the nut to a torque of 100 Nm.

Adjustment and lubrication of wheel bearings

1. Dismount the wheel (See "*Dismounting/Mounting Wheels*").
2. Remove the hubcap.
3. Take out the split cotter pin.
4. Tighten the castle nut 1/6 of a rotation until the hole is lined up with the axle. The hub must be turned just enough so that there is no drag on the bearing, yet there must not be so much slack in the hub that it jiggles from side to side. If there still is some slack in the hub, repeat the process.
5. Replace the split cotter pin.
6. Fill the hubcap $\frac{3}{4}$ full with lubricant and reinstall.

For wheel mounting, see "*Dismounting/mounting of wheels*".

General Information

Avoid spilling oil on the ground. If this should happen, collect as much oil as possible and dispose of it properly.

If the harrow is parked in an area of high humidity or dampness for a prolonged period of time, apply oil or grease to the piston rods to prevent rust from developing.

Cleaning and Inspection

At the end of the season, clean off any soil or plant material that could absorb moisture. This will facilitate later inspection of the machinery or any possible repairs.

Options

The AXR-H can be equipped with various types of optional accessories. It is also possible to equip the AXR-H to be fully hydraulic

Hydraulic Angle Adjustment

Hydraulic angle adjustment makes it possible to change the angle of the discs from inside the cab while driving on the field.

Fig. 20



Mounting

1. Unfold the AXR-H and lower it onto the ground.
2. Remove the turnbuckles from the brackets (A).
3. Mount the hydraulic angle adjustment into the brackets.
4. Mount the disc gang turnbuckles onto the hydraulic angle adjustment.
5. Fasten the hydraulic hoses to the main frame (**Make sure that the hoses do not get caught or squeezed when the side wings fold up into the transport position.**).
6. Connect the hydraulic hoses to a double-acting outlet on the tractor. Activate the angle adjustment in the fully extended position to bleed air out of the system.
7. Check the hydraulic system for leaks.

▽

Never allow bystanders within the operating radius of the AXR-H when the angle adjustment is activated.

Table 7. Hydraulic Hose Markings

Function	Colour
Angle adjustment	Blue

Operating Instructions

Hydraulic angle adjustment provides the user with greater flexibility since it allows the user to react immediately to the changes in the field structure. The optimum setting can be more easily attained when the results of the angle changes can be seen immediately. It is recommended not to drive with a larger angle than necessary, since this will increase wear on the machinery and

more power will be required from the tractor to pull the unit. (*"Operating Instructions, Levelling Position"*).

Maintenance

Tighten all nuts, bolts, hydraulic fittings or any other fastened assemblies after the first workday.

Lubricate the hydraulic angle adjustment after every 25 working hours. If the angle adjustment is frequently used, it is best to lubricate it more often.

Electro-Hydraulic Operation

Electro-hydraulic operation requires only one double-acting service on the tractor. AXR-H's functions are accessed through four electronic sockets that are mounted in a box located on the tractor.

Electro-hydraulic operation is particularly an advantage when there is a lack of hydraulic services on the tractor. Hitching of the implement also becomes much easier since there are only two hydraulic hoses to be connected to the tractor.

To activate a function, turn on the switch related to the function and move the hydraulic handle. After completing the operation, turn off the switch and another function can be activated. A function that is frequently used for field work can be left on, and in this case, the hydraulic handle can simply be moved when needed.

A green light is lit when a switch is activated. When shifting to another function, the previous switch must be turned off first since only one switch may be on at a time. There is a green indicator light associated with each switch that lights when that particular function is activated.



After mounting optional accessories, the hydraulic system must be thoroughly bled for air. This can be done by moving the cylinders into the fully extended and retracted positions. Check to make sure that there are no hoses caught, squeezed or ripped off after mounting of the new accessories has been completed.

Bearing Protectors

Bearing protectors can be mounted on the disc bearings if you wish to have extra protection for the bearing housings. Bearing protectors are installed in the holes that hold the bearings and replace the original bolts.

Mounting

Mounting of the bearing protectors must be carried out while the AXR-H is in the unfolded position and is resting on the ground. Remove the bolts from one bearing at a time and mount the bearing protector, then continue on to the next bearing. Before starting to dismount the bearings, make sure that the bearings are clean.

Fig. 21

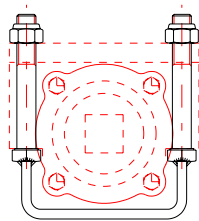

Replacements and Repairs

Safety is important in connection with **all** repair work on the AXR-H. The following safety precautions must be observed:

- ▽ When performing repair or maintenance work on the AXR-H, the implement must first be resting properly and securely on the ground.
- ▽ It is **extremely dangerous** to work or walk under the AXR-H when it has been raised by the lift/lifted on the wheel frame unless the implement is securely supported or held into position. The engine of the tractor must be stopped and the brakes must be locked.
- ▽ After making repairs to the hydraulic system, always bleed air out of the system before operating the harrow again to avoid any possible personal injury or mechanical breakdown or damage.
- ▽ Never allow bystanders within the operating radius of the AXR-H while the hydraulic units are in operation. This area is considered to be fatally dangerous.
- ▽ When dismounting/mounting components, always pay careful attention to the weight of the part you are about to handle. It is important to support or secure the part so that it cannot fall.

Replacing Disc Bearings

Before changing the bearings, the AXR-H must be hitched to a tractor and the implement must be unfolded and resting securely on the ground. Lower the transport wheels on the AXR-H so that the wheels just barely carry the weight of the AXR-H, but the discs are still resting on the ground.

Fig. 24



1. Remove the bolt (A) (if bearing protectors are mounted on the bearings, first remove the nuts, and then the bearing protectors can be removed).
2. After the bolts have been removed raise the AXR-H. Discs and shaft can then be rolled away or the AXR-H can be moved away. (**If work is per-**

formed under the AXR-H when it is raised on the wheel frame and/or has been raised by the lift, the AXR-H must be supported).

3. Remove the split cotter pin from the castle nut and unscrew the nut. The spacers, discs and bearings can then be pulled off the shaft. Be careful not to damage the screw thread on the shaft.

Mounting discs and bearings

1. Clean the shaft, discs and bearings.
2. Assemble the discs, spacers and bearings while they are still on the floor (see Table 8). Be careful not to damage the screw thread on the shaft. The end of the shaft can be gently tapped with a hammer to get the pieces to move to the bottom.
3. After the last disc has been placed onto the shaft, assemble (1) end washer, (2) clamp and (3) castle nut. It is recommended that the final tightening of the nut be carried out after the shaft has been mounted onto the AXR-H.
4. Roll the assembled shaft under the AXR-H. The holes of the bearings must be lined up with the flanges of the AXR-H. **(Performing repairs or maintenance work under the AXR-H when it is raised from the ground requires strong support from underneath. No one is allowed under the AXR-H unless it is firmly blocked and supported.)**
5. Lower the AXR-H carefully to within a few mm of the bearings. Insert the bolts. Use extreme caution when performing this procedure. Before making final adjustments to the shaft and inserting the bolt, the AXR-H must be securely blocked and held in place.
6. After tightening the bolts in the bearings, tighten the castle nut to a torque of 2000 Nm (200 kgm) and insert the split cotter pin.

Make sure that the spacers and the bearings are facing in the right direction so that the ends are positioned up against the discs.

Table 8

Model	Disc gang	1	2	3	4	5	6	7	8	9	10	11	12	13	14	15	Shaft length
AXR-H 400	9 disc front	S	B	N	S	N	B	S	N	S	N	B	S				2019
	10 discs back	s	N	B	S	N	S	N	B	S	N	S	B	N			2253
AXR-H 450	10 discs front	S	B	N	S	N	S	B	N	S	N	S	B	N			2253
	11 discs back	s	S	B	N	S	N	S	B	N	S	N	S	B	N		2487
AXR-H 500	11 discs front	S	B	N	S	N	S	B	N	S	N	S	N	B	S		2487
	12 discs back	s	N	S	B	N	S	N	S	B	N	S	N	S	B	N	2721
AXR-H 600	8 discs front inside	S	B	N	S	N	B	S	N	S	B	N					1785
	5 discs front outside	S	B	N	S	N	B	S									1083
	8 discs back inside	S	B	N	S	N	B	S	N	S	B	N					1785
	6 discs back outside	s	N	B	S	N	S	B	N								1317

N = NOTCHED DISC
 S = SMOOTH DISC
 s = SMALL DISC (smooth)
B = BEARING

Replacing the bearings in the housings

Fig. 25

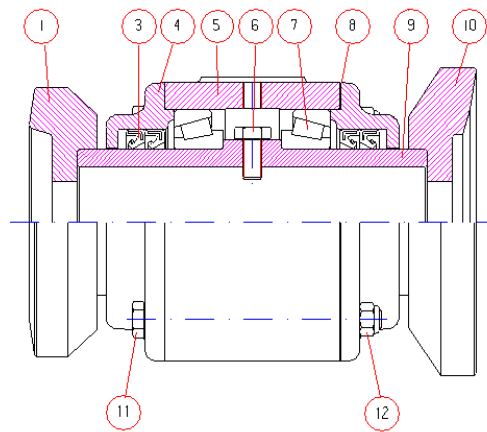

- 1. Flange Ø138 inside the dish
- 3. Lip seals 75/95/10
- 4. Cover with lip seals
- 5. Housingb
- 6. Bolt 10x20 mm
- 7. Bearing 32015x
- 8. Cover sealing
- 9. Hollow shaft
- 10. Flange Ø138 inside the dish
- 11. Bolt 10x120 mm
- 12. Nut M12

1. Remove the flanges (pos. 1+10) from the bearing housing.
2. Remove the 4 bolts (4 pieces, pos. 11) that hold the covers to the housing, and lift the covers (pos. 4) off both sides of the housing.
3. Press out the lip seals (pos. 3) in each cover (pos. 4). Since lip seals must be in extremely good condition in order to use them again, it is generally suggested that they be replaced.
4. Press the bearings (pos. 7) out of the housing by means of a hydraulic press. The bearings can also be knocked out of the housing by tapping on the hollow shaft (pos. 9), but the hollow shaft must be protected with a wooden block. (The hollow shaft is constructed with a collar in the middle which presses the bearing out when you knock on the shaft). If the bearings are very worn, the inner ring may remain inside the housing. Tap the inner ring out with a mandrel. Be careful not to damage the housing.
5. Press or knock the inner ring out of the hollow shaft (pos. 9).
6. Clean all parts that will be used again.

Assembly

1. Mount the outer ring into the housing (Since these bearings are conical roller bearings, it is important that the outer ring is facing in the right direction so that the outer ring matches the inner ring).
2. Mount the inner ring of the bearing onto the hollow shaft (Remember that the inner rings must be facing in the right direction so that they match the outer rings). Press the inner rings all the way out to collar of the hollow shaft.
3. Mount the hollow shaft together with the inner ring of the bearings into the bearing housing.
4. Mount the other outer ring into the bearing housing. Turn the hollow shaft so that the rollers in the bearing match with the outer and inner rings
5. Replace the lip seals. It is important that the lip seals be fitted in correctly so that soil or debris cannot penetrate the bearing and so that grease can be

- pressed out of the bearing in case of over-lubrication. Replace the covers onto the inner part and bolt them firmly to the bearing housing.
6. Replace the flanges (pos. 1+10).

Replacing T-Ring Packer Roller Bearings

When changing the bearings on the packer roller, loosen the scrapers and the bearings at the same time since the same bolt holds them both.

Fig. 26



1. Remove the bearings. The shaft with the T-rings is now free, and the shaft can be rolled backwards.
2. Loosen the set screws.
3. Remove the bolts at the end of the shaft.
4. Dismount the T-rings.

Mounting

1. After replacing the bearings, mount the T-rings. Make sure that the T-rings and the bearings are facing in the right direction (see spare parts drawing).
2. If necessary, place washers in between them to eliminate slack. Secure the set screws with Loctite.

Replacing Scrapers

Change the scrapers when they are so worn that they no longer can perform satisfactorily.

Packer Roller Scrapers

The scrapers and bearings on the packer roller shaft are held by the same bolts. For removal of the scrapers (*see "Replacing the bearings on the T-ring packer roller"*).

Disc scrapers

To change the disc scrapers, the AXR-H must be unfolded in the working position. The scrapers are mounted onto the disc gang with three bolts. Remove the bolts and mount a new scraper. Notice that the scrapers on the right/left sides as well as the scrapers on the front and back gangs are different. For adjustment of the scrapers (see *Adjustments and Settings, Scrapers*).

Replacing Discs

Change the discs when they are so worn that they cannot perform satisfactorily. (See *Replacing Disc Bearings*)

Replacing T-Rings

Change the T-rings by following the procedure under (*Replacing T-Ring Packer Roller Bearings*).

Fig. 27



Replacing Drawbar Bushings

If there is slack in the drawbar when you lift in the lift arm connection, this is a sign that the bushings are worn. On top of the vertical turning axle there is a glacier washer to absorb pressure, and inside the tube there are two bushings.

Fig. 28

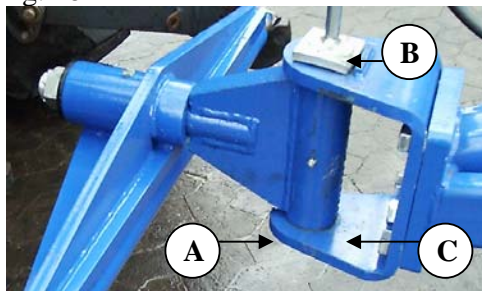

1. Unhitch the AXR-H from the tractor and rest it on the support bar.
2. Remove the bolt (A) together with the washer, and then the axle (B) can be pulled out. **It is important to suspend the drawbar with a strap so that the drawbar is hanging in balance.**

3. The top glacier washer falls off when the drawbar is removed from the bracket (C). Knock the bushings out of the tube with a suitably sized mandrel.

Mounting

1. Clean all parts.
2. Insert the new bushings in the tube. Tap the bushings all the way down to the collar in the tube.
3. Mount the drawbar into the bracket. Remember to replace the top glacier washer (the yellow Teflon coating should point down towards the tube).
4. Mount the shaft (B) and assemble the bolt and the washer (A) and tighten.
Remember to secure the bolt with Loctite.

Replacing Packer Roller Arm Bushings

The slack can be checked by raising the AXR-H on the wheel frame with the arms of the packer roller completely unfolded. Using your hands, grab onto the outside arm of the packer roller and move it back and forth. If there is too much slack inside the arm of the packer roller, the bushings are worn.

Fig. 29

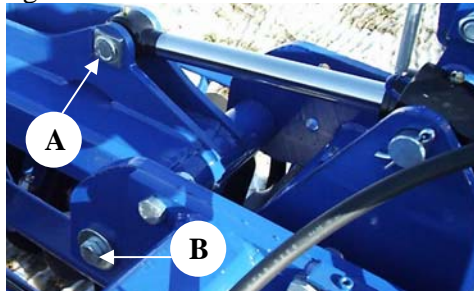

Seen from the front

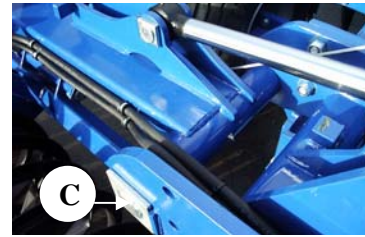

Seen from the back

1. Follow points 1 to 3 under ("*Replacing Packer Roller Centre Pin*").
2. If there is hydraulic depth adjustment on the packer roller, dismantle the hoses that are attached to the arm.
3. Remove the pin (A).
4. Suspend the arm of the packer roller with two straps so that the arm is hanging in balance.
5. Remove the bolt (B).
6. Pull out the pin (C), and the arm is now free.
7. Knock out the bushings and replace them with new ones.
8. Reassemble the arm in reverse order.

Replacing Packer Roller Centre Pin

1. Follow points 1 to 3 under "Replacing Packer Roller Depth Adjustment Bushings".
2. Suspend from the pivot.
3. Tap out the slotted split pin (B) and unscrew the castle nut. Pull out the pin (C).
4. Insert the new pin, screw on the castle nut and tighten to a torque 100 Nm, or until there is no gap between the plates when AXR-H is resting on the packer roller. Loosen the castle nut until the notch of the castle nut lines up with the hole in the shaft. Remember to insert the slotted split pin.

Dismounting Disc Gangs

It is recommended that a crane is available for the dismounting of the disc gangs.

Fig.31

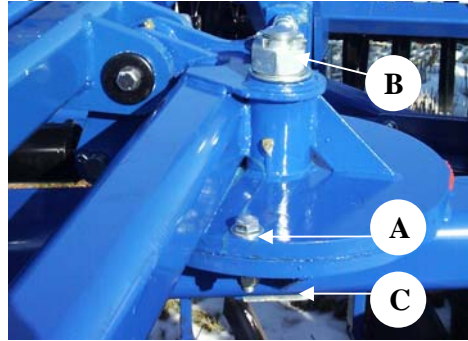

1. The AXR-H must be hitched to a tractor and unfolded, and it must be resting in a secure position on the ground.
2. Suspend the disc bars with two straps so that the disc gangs are hanging in balance. The straps and the crane must be able to carry 500 kg.
3. Lift until the weight of the disc gangs is carried by the straps.
4. Remove the bolt (A).
5. Remove the split cotter pin and the castle nut (B).
6. Raise the AXR-H carefully with the tractor's lift and also by means of the wheel frame on the AXR-H, so that the main frame is pulled out of the pin. The crane should not lift the disc gangs, but rather just support the disc gangs so that they do not tip over when the pin is pulled out of the bushing.
7. It is necessary to dismount the disc shaft in order to change the pin (C). (See "Replacing Disc Bearings") **Note:** The pin (C) must be placed in the bushing of the gang **before** the disc shaft is fitted onto the gang.
8. Reassemble in reverse order.

∇

Take precautions to ensure that the disc shaft does not roll away unintentionally.

Replacing Hydraulic Hoses

Defective hydraulic hoses must be replaced immediately. A ruptured hose could cause personal injury to the user or mechanical damage to the equipment. Read more under the changing of the cylinders for the respective hoses.

Replacing Side Wing Folding Cylinders

The AXR-H must be unfolded and lowered down so that the discs are resting on the ground. It is important to remove the pressure from the cylinders.

Fig.33



1. Remove the hoses. To avoid ground pollution, it is suggested that you collect the oil in a tray placed underneath the working area while making repairs to the machine.
2. Remove the split cotter pins and the pins. The cylinders are now free.
3. Mount a new cylinder in reverse order. Remember to make sure that the pin is engaged in the stop and that the pin is secured with a split cotter pin.



After mounting the new cylinder, carefully lift and lower the side sections several times to bleed air out of the system. Never allow bystanders within the operating radius of the implement.

Changing the seals on the side wing folding cylinders

For removal of the cylinder, see "*Replacing Side Wing Folding Cylinders*".

Fig. 34

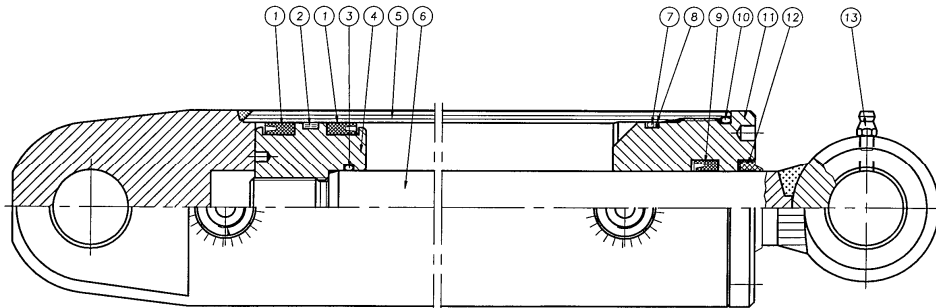

Cylinder 70/30-205

1. Empty the oil from the cylinder by moving the cylinder back and forth.

2. Move the piston to the middle position. Unscrew the gland (pos. 11) approximately 25 mm out. (A special tool is needed to remove the gland). If the gland is stuck, it may help to warm up the very front of the socket. When the gland has been unscrewed, pull out the piston towards the gland. Pull the piston rod (pos. 6) completely out of the cylinder casing (pos. 5).
3. Remove the self-locking nut from the bottom of the piston rod.
4. Pull the sleeve off the piston rod (pos. 4).
5. Pull the gland off the piston rod (pos. 11).
6. Remove the seals from the gland and the sleeve (pos. 1+2+3+7+8+9+10+12).
7. Clean all parts thoroughly. Check for filings, shavings, burrs and make sure that there is no rust around the scraper ring (pos. 12) in the gland. If this is the case, it must be removed.

Assembly

1. Assemble the new seals into the gland and the sleeve.
2. Lubricate the screw threads on the gland (pos. 11) and the cylinder casing with grease or a corrosion-inhibiting, anti-seize lubricant.
3. Mount the gland (pos. 11) onto the piston rod.
4. Mount the sleeve (pos. 4) and screw on the self-locking nut with Loctite. Make sure that the screw threads are completely clean and free from oil or other impurities before using Loctite. **Do not refill the oil for the first 12 hours after the application of Loctite.**
5. Lubricate the sleeve (pos. 4) and the inside of the cylinder casing, then guide the piston rod into the middle position of the casing.
6. Screw on the gland and tighten.
7. Mount the cylinder. Remember to make sure that the pin is engaged in the stop and that the pin is secured with a split cotter pin.
8. Attach the hoses. Make sure that the hoses are not caught or squeezed in any way and that the connections are airtight.

▽ Watch for places where the hoses could possibly be ripped off or become squeezed or caught in the equipment.

▽ After mounting the cylinder, carefully raise and lower the side wings several times to bleed air out of the hydraulic system. Lift the side wings only approximately 20 to 25 degrees from the working area so that the side wings can be lowered to the same side from which they were lifted.

▽ Never allow bystanders within the operating radius of the AXR-H while the hydraulic units are in operation. This area is considered to be fatally dangerous.

Replacing Wheel Frame Cylinder

The AXR-H must first be unfolded and lowered so that the discs are resting securely on the ground. Relieve the pressure in the wheel cylinder so that the wheels are resting on the ground.

1. Dismount the hoses. (To avoid ground pollution, it is recommended that you collect the oil in a tray placed underneath the working area while carrying out repairs on the implement.)
2. Remove the split cotter pin and the pin. The cylinder is now free.
3. Mount the cylinder in reverse order. Remember to make sure that the pin is engaged in the stop and that the pin is secured with a split cotter pin.

▽

After mounting the cylinder, carefully raise and lower the AXR-H several times to bleed air out of the system. Initially, the AXR-H must not be lifted higher than 10-20 cm from the ground. Never allow bystanders within the operating radius of the AXR-H.

Changing the seals on the wheel frame cylinder

Fig. 35

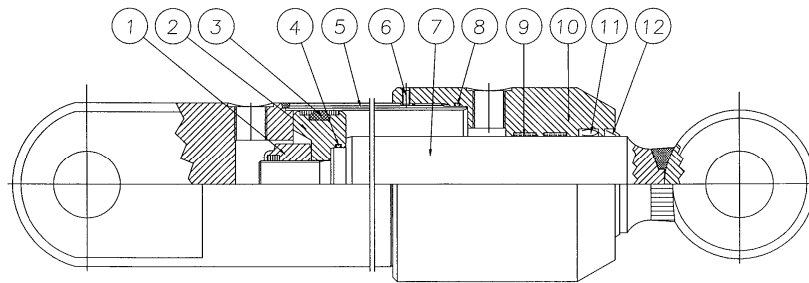

Cylinder 80/50-350

1. Empty the oil from the cylinder by moving the cylinder back and forth.
2. Move the piston to the middle position. Unscrew the gland (pos. 10) from the cylinder casing (pos. 5). A special tool is needed to remove the gland. If the gland is stuck, it may help to warm up the very front of the socket. When the gland has been unscrewed, pull the piston out towards the gland. Pull the piston rod (pos. 7) out of the cylinder casing (pos. 5).
3. Remove the locking nut (pos. 1) which holds the sleeve (pos. 2).
4. Pull the sleeve (pos. 2) off the piston rod (pos. 7).
5. Pull the gland (pos. 10) off the piston rod (pos. 7).
6. Remove the seals from the gland and the sleeve (pos. 3+4+6+8+9+11+12).
7. Clean all parts thoroughly. Check for filings, shavings, burrs and make sure that there is no rust around the scraper ring (pos. 12) in the gland. If this is the case, it must be removed.

Assembly

1. Assemble the new seals into the gland and the sleeve (pos. 3+4+6+8+9+11+12).
2. Lubricate the screw threads on the gland (pos. 10) and the cylinder casing (pos. 5).
3. Place the gland (pos. 10) onto the piston rod (pos. 7).
4. Mount the sleeve (pos. 2) and screw on the self-locking nut **with Loctite**. Make sure that the screw threads are completely clean and free from oil or other impurities before using Loctite. **Do not refill the oil for the first 12 hours after the application of Loctite.**
5. Lubricate the outermost seal on the sleeve which has contact with the cylinder casing and the inside of the cylinder casing with oil, and then guide the piston into the middle position.
6. Fit the gland onto the cylinder casing and tighten.
7. Mount the cylinder.
8. Attach the hoses. Make sure that the hoses are not caught or squeezed in any way and that the connections are airtight.



After mounting the cylinder, carefully raise and lower the AXR-H several times to bleed air out of the system. Initially, do not lift the AXR-H higher than approximately 10-20 cm off the ground. Never allow bystanders within the operating radius of the AXR-H.

Replacing Packer Roller Folding Cylinders

The AXR-H must be unfolded and lowered so that the packer roller is resting securely on the ground. Important: Relieve the pressure in the cylinders.

1. Dismount the hoses. (To avoid ground pollution, it is recommended that you collect the oil in a tray placed underneath the working area while carrying out repairs on the implement.).
2. Remove the split cotter pins and pins. The cylinder is now free.
3. Mount the cylinder in reverse order. Remember to make sure that the pin is engaged in the stop and that the pin is secured with a split cotter pin.



After mounting the cylinder, carefully raise and lower the AXR-H several times to bleed air out of the system. Do not raise the packer roller so high that it cannot be lowered down again. Never allow bystanders within the operating radius of the AXR-H.

Changing the seals on the packer roller cylinder

Fig.36

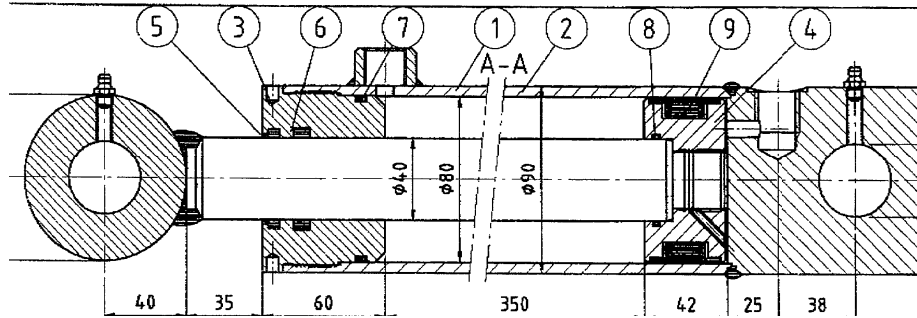

Cylinder 80/40-350

1. Empty the oil from the cylinder by moving the cylinder back and forth.
2. Move the piston into the middle position. Unscrew the gland (pos. 3) from the cylinder casing (pos. 1). A special tool is needed to remove the gland. If the gland is stuck, it may help to warm up the very front of the socket. When the gland has been unscrewed, pull the piston out towards the gland. Pull the piston rod out of the cylinder casing (pos. 1).
3. Remove the locking nut which holds the sleeve (pos. 4).
4. Pull the sleeve (pos. 4) off the piston rod (pos. 2).
5. Pull the gland (pos. 3) off the piston rod (pos. 2).
6. Remove the seals from the gland and the sleeve (pos. 5+6+7+8+9).
7. Clean all parts thoroughly. Check for filings, shavings, burrs and make sure that there is no rust around the scraper ring (pos. 5) in the gland. If this is the case, it must be removed.

Assembly

1. Assemble the new seals into the gland and the sleeve (pos. 5+6+7+8+9).
2. Lubricate the screw threads on the gland (pos. 3) and the cylinder casing (pos. 1).
3. Place the gland (pos. 3) onto the piston rod.
4. Mount the sleeve (pos. 4) and screw on the self-locking nut **with Loctite**. Make sure that the screw threads are completely clean and free from oil or other impurities before using Loctite. **Do not refill the oil for the first 12 hours after the application of Loctite.**
5. Lubricate the outermost seal on the sleeve which has contact with the cylinder casing and the inside of the cylinder casing with oil, then guide the piston into the middle position.
6. Fit the gland onto the cylinder casing and tighten.
7. Mount the cylinder.
8. Attach the hoses. Make sure that the hoses are not caught or squeezed in any way and that the connections are airtight.



After mounting the cylinder, carefully raise and lower the packer roller several times to bleed air out of the system. Do not raise the packer roller so high that it cannot be lowered down again. Never allow bystanders within the operating radius of the implement.

Replacing Angle Adjustment Cylinders

The AXR-H **must be unfolded** and lowered with the side wings resting securely on the ground.



It is important to relieve pressure in the angle adjustment cylinder.

1. Remove the hydraulic fittings from the cylinder.
2. Remove the pins. The cylinder can now be lifted out.
3. Assemble the hydraulic angle adjustment in reverse order.



After assembling the hydraulic angle adjustment, bleed air out of the system by moving the cylinder back and forth to the fully extended and retracted positions. **Always bleed air out of the system while the machine is unfolded.**



Never allow bystanders within the operating radius of the implement when operating the angle adjustment.

Fig.37

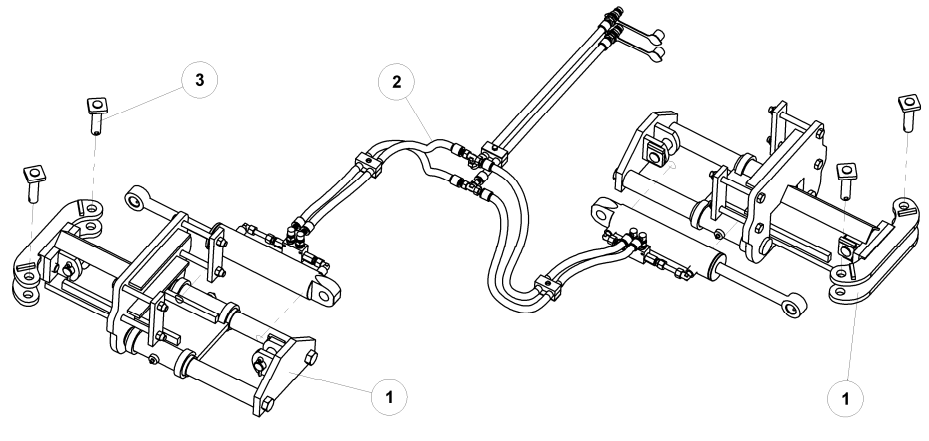

Changing the seals on the angle adjustment cylinders

Fig. 38

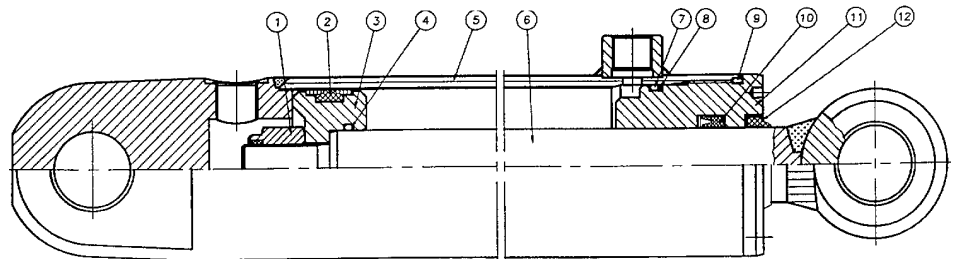

Cylinder 63/30-205

1. Empty the oil from the cylinder by carefully moving the cylinder back and forth.
2. Move the piston into the middle position. Unscrew the gland (pos. 11) from the cylinder casing (pos. 5). A special tool is needed to remove the gland. If the gland is stuck, it may help to warm up the very front of the socket. When the gland has been unscrewed, pull the piston out towards the gland. Pull the piston rod (pos. 6) out of the cylinder casing (pos. 5).
3. Remove the locking nut (pos. 1) which holds the sleeve (pos. 3).
4. Pull the sleeve (pos. 3) off the piston rod (pos. 6).
5. Pull the gland (pos. 11) off the piston rod (pos. 7).
6. Remove the seals from the gland and the sleeve (pos. 2+4+7+8+9+10+12).
7. Clean all parts thoroughly. Check for filings, shavings, burrs and make sure that there is no rust around the scraper ring (pos. 12) in the gland. If this is the case, it must be removed.

Assembly

1. Assemble the new seals into the gland and the sleeve (pos. 2+4+7+8+9+10+12).
2. Lubricate the screw threads on the gland (pos. 11) and the cylinder casing (pos. 5) with grease or oil.
3. Place the gland (pos. 11) onto the piston rod (pos. 6).
4. Mount the sleeve (pos. 3) and screw on the self-locking nut **with Loctite**. Make sure that the screw threads are completely clean and free from oil or other impurities before using Loctite. **Do not refill the oil for the first 12 hours after the application of Loctite.**
5. Lubricate the outermost seal on the sleeve which has contact with the cylinder casing and the inside of the cylinder casing with oil, then guide the piston into the middle position.
6. Fit the gland onto the cylinder casing and tighten.
7. For mounting the cylinder (*see "Replacing Angle Adjustment Cylinders"*).

▽

After mounting the cylinder, bleed air out of the system by activating the angle adjustment so that the cylinders move out into the fully extended and retracted positions. Never allow bystanders within the operating radius of the implement.

Replacing hydraulic lock cylinders on the disc gangs

The AXR-H **must be unfolded** and lowered with the side wings resting securely on the ground.

▽

It is important to relieve pressure in the locking system cylinders.

▽

After mounting the cylinder and hoses, bleed air out of the system by moving the cylinder back and forth to the fully extended and retracted positions.

Fig. 39

1. Remove the mounting bracket.
2. Remove the bolts fastening the cylinder.
3. Mount in reverse order.



Changing the seals on the hydraulic lock cylinders

1. Empty the oil from the cylinder by moving the cylinder back and forth.
2. Move the piston into the middle position. Unscrew the gland from the cylinder casing. A special tool is needed to remove the gland. If the gland is stuck, it may help to warm up the very front of the socket. When the gland has been unscrewed, pull the piston out towards the gland. Pull the piston rod out of the cylinder casing.
3. Remove the locking nut which holds the sleeve.
4. Pull the sleeve off the piston rod.
5. Pull the gland off the piston rod.
6. Remove the seals from the gland and the sleeve.

Clean all parts thoroughly. Check for filings, shavings, burrs and make sure that there is no rust around the scraper ring in the gland. If this is the case, it must be removed.

Assembly

1. Assemble the new seals into the gland and the sleeve.
2. Lubricate the screw threads on the gland and the cylinder casing.
3. Place the gland onto the piston rod.
4. Mount the sleeve and screw on the self-locking nut **with Loctite**. Make sure that the screw threads are completely clean and free from oil or other impurities before using Loctite. **Do not refill the oil for the first 12 hours after the application of Loctite.**
5. Lubricate the outermost seal on the sleeve which has contact with the cylinder casing and the inside of the cylinder casing with oil, then guide the piston into the middle position.
6. Place the gland onto the cylinder casing and tighten.

Replacing Wheel Bearings

1. Dismount the wheel. For dismounting of the wheel (see "Dismounting/mounting of wheels" under the section "Maintenance").
2. Remove the hubcap (pos. 21).
3. Take out the split cotter pin (pos. 20).

4. Unscrew the castle nut (pos. 19).
5. Carefully knock off the hub (pos. 22) and remove the bearings.
6. Remove the seal (pos. 16).
7. Remove the outer ring from the bearing.
8. Clean all parts.

Fig. 40

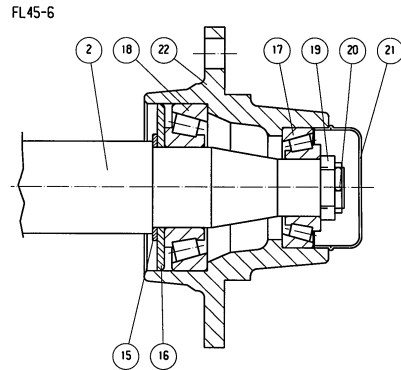

Assembly

1. Mount the outer ring from the bearings into the hub (pos. 22).
2. Place the seal (pos. 16) onto the axle.
3. Place the inner ring from the large bearing onto the axle and replace the hub.
4. Place the inner ring from the little bearing onto the axle.
5. Screw the castle nut onto the axle and turn the hub at the same time. Tighten the nut until there is a slight drag on the wheel as it is turning. Next, loosen the castle nut and back off until the split cotter pin is lined up with a hole in the axle and also the castle nut. (If the wheel is still sluggish when it turns, loosen the castle nut until the next hole in the axle is lined up with the nut.
6. Replace the split cotter pin.
7. Fill the hubcap $\frac{3}{4}$ full with grease and reinstall. For mounting of the wheel (see "Dismounting/Mounting of Wheels").

Hydraulic diagram 400/500/600

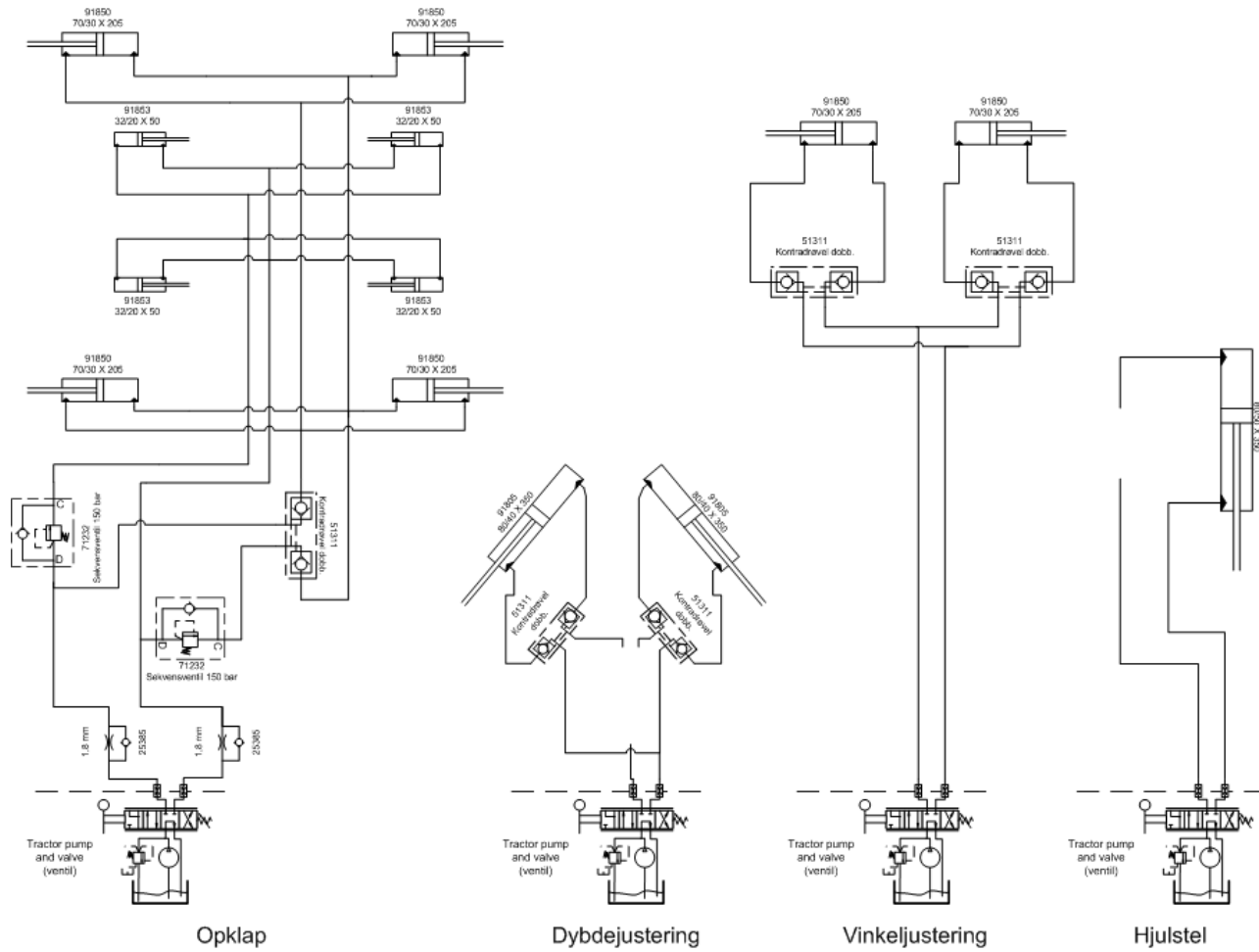

Scrapping

The AXR-H must be unfolded and the side sections must be lowered with the packer roller resting securely on the ground. It is important to relieve the pressure in **all** of the cylinders.

▽ When dismantling/mounting components, always pay careful attention to the weight of the part that you are about to handle. It is important to support or secure the part so that it cannot fall. (It is an advantage if a crane is available.)

▽ In case skin should come in contact with oil or grease or in case clothing should become stained with oil, remove the stained clothes immediately and wash the affected skin areas thoroughly.

Dismount all hydraulic hoses and cylinders and empty the oil. To avoid pollution of the ground and the surrounding area, collect the oil. Dispose of the oil and the hoses properly.

Dismount the side sections, the packer roller and the disc gangs. (See “*Replacement and Repairs*” for details.)

All iron used in the machine is recyclable.

Spareparts